

ISSN 2518-170X (Online)

ISSN 2224-5278 (Print)

**NEWS OF THE NATIONAL ACADEMY
OF SCIENCES OF THE REPUBLIC
OF KAZAKHSTAN, SERIES OF
GEOLOGY AND TECHNICAL SCIENCES**

№2

2026

ISSN 2518-170X (Online)

ISSN 2224-5278 (Print)



N E W S
OF THE NATIONAL ACADEMY OF SCIENCES
OF THE REPUBLIC OF KAZAKHSTAN,
SERIES OF GEOLOGY AND TECHNICAL
SCIENCES

2 (476)
MARCH – APRIL 2026

THE JOURNAL WAS FOUNDED IN 1940

PUBLISHED 6 TIMES A YEAR

ALMATY, 2026

The scientific journal News of the National Academy of Sciences of the Republic of Kazakhstan, Series of Geology and Technical Sciences has been indexed in the international abstract and citation database Scopus since 2016 and demonstrates stable bibliometric performance.

The journal is also included in the Emerging Sources Citation Index (ESCI) of the Web of Science platform (Clarivate Analytics, since 2018).

Indexing in ESCI confirms the journal's compliance with international standards of scientific peer review and editorial ethics and is considered by Clarivate Analytics as part of the evaluation process for potential inclusion in the Science Citation Index Expanded (SCIE), Social Sciences Citation Index (SSCI), and Arts & Humanities Citation Index (AHCI).

Indexing in Scopus and Web of Science ensures high international visibility of publications, promotes citation growth, and reflects the editorial board's commitment to publishing relevant, original, and scientifically significant research in the fields of geology and technical sciences.

«Қазақстан Республикасы Ұлттық ғылым академиясының Хабарлары. Геология және техникалық ғылымдар сериясы» ғылыми журналы 2016 жылдан бастап халықаралық реферативтік және ғылымиметриялық Scopus дерекқорында индекстеледі және тұрақты библиометриялық көрсеткіштерді көрсетіп келеді.

Сонымен қатар журнал Web of Science платформасының (Clarivate Analytics, 2018) халықаралық реферативтік және наукометриялық дерекқоры Emerging Sources Citation Index (ESCI) тізіміне енгізілген.

ESCI дерекқорында индекстелуі журналдың халықаралық ғылыми рецензиялау талаптары мен редакциялық этика стандарттарына сәйкестігін растайды, сондай-ақ Clarivate Analytics компаниясы тарапынан басылмды Science Citation Index Expanded (SCIE), Social Sciences Citation Index (SSCI) және Arts & Humanities Citation Index (AHCI) дерекқорларына енгізу қарастырылуда.

Scopus және Web of Science дерекқорларында индекстелуі жарияланымдардың халықаралық деңгейде жоғары сұранысқа ие болуын қамтамасыз етеді, олардың дәйексөз алу көрсеткіштерінің артуына ықпал етеді және редакциялық алқаның геология мен техникалық ғылымдар саласындағы өзекті, бірегей және ғылыми тұрғыдан маңызды зерттеулерді жариялауға ұмтылысын айқындайды.

Научный журнал «News of the National Academy of Sciences of the Republic of Kazakhstan, Series of Geology and Technical Sciences» с 2016 года индексируется в международной реферативной и наукометрической базе данных Scopus и демонстрирует стабильные библиометрические показатели.

Журнал также включён в международную реферативную и наукометрическую базу данных Emerging Sources Citation Index (ESCI) платформы Web of Science (Clarivate Analytics, 2018).

Индексирование в ESCI подтверждает соответствие журнала международным стандартам научного рецензирования и редакционной этики, а также рассматривается компанией Clarivate Analytics в рамках дальнейшего включения издания в Science Citation Index Expanded (SCIE), Social Sciences Citation Index (SSCI) и Arts & Humanities Citation Index (AHCI).

Индексирование в Scopus и Web of Science обеспечивает высокую международную востребованность публикаций, способствует росту цитируемости и подтверждает стремление редакционной коллегии публиковать актуальные, оригинальные и научно значимые исследования в области геологии и технических наук.

EDITOR-IN-CHIEF

ZHURINOV Murat Zhurinovich, Doctor of Chemical Sciences, Professor, Academician of IAAS and NAS RK, General Director of the Research Institute of Petroleum Refining and Petrochemicals (Almaty, Kazakhstan), <https://www.scopus.com/authid/detail.uri?authorId=6602177960>; <https://www.webofscience.com/wos/author/record/2017489>

DEPUTY EDITOR-IN-CHIEF

ABSADYKOV Bakhyt Narikbayevich, Doctor of Technical Sciences, Professor, Academician of NAS RK, Satbayev University (Almaty, Kazakhstan), <https://www.scopus.com/authid/detail.uri?authorId=6504694468>; <https://www.webofscience.com/wos/author/record/2411827>

EDITORIAL BOARD:

ABSAMETOV Malis Kudysovich, Doctor of Geological and Mineralogical Sciences, Professor, Academician of NAS RK, Director of the U.M. Akhmedsafin Institute of Hydrogeology and Geocology (Almaty, Kazakhstan), <https://www.scopus.com/authid/detail.uri?authorId=56955769200>; <https://www.webofscience.com/wos/author/record/1937883>

ZHOLTAEV Geroy Zholtaevich, Doctor of Geological and Mineralogical Sciences, Professor, Honorary Academician of NAS RK (Almaty, Kazakhstan), <https://www.scopus.com/authid/detail.uri?authorId=57112610200>; <https://www.webofscience.com/wos/author/record/1939201>

SNOW Daniel, PhD, Associate Professor, Director, Aquatic Sciences Laboratory, University of Nebraska (Nebraska, USA), <https://www.scopus.com/authid/detail.uri?authorId=7103259215>; <https://www.webofscience.com/wos/author/record/1429613>

SELTMANN Reimar, PhD, Head of Petrology and Mineral Deposits Research in the Earth Sciences Department, Natural History Museum (London, Great Britain), <https://www.scopus.com/authid/detail.uri?authorId=55883084800>; <https://www.webofscience.com/wos/author/record/1048681>

PANFILOV Mikhail Borisovich, Doctor of Technical Sciences, Professor at the University of Nancy (Nancy, France), <https://www.scopus.com/authid/detail.uri?authorId=7003436752>; <https://www.webofscience.com/wos/author/record/1230499>

SHEN Ping, PhD, Deputy Director of the Mining Geology Committee of the Chinese Geological Society, Member of the American Association of Economic Geologists (Beijing, China), <https://www.scopus.com/authid/detail.uri?authorId=57202873965>; <https://www.webofscience.com/wos/author/record/1753209>

FISCHER Axel, PhD, Associate Professor, Technical University of Dresden (Dresden, Germany), <https://www.scopus.com/authid/detail.uri?authorId=35738572100>; <https://www.webofscience.com/wos/author/record/2085986>

AGABEKOV Vladimir Enokovich, Doctor of Chemical Sciences, Academician of NAS of Belarus, Honorary Director of the Institute of Chemistry of New Materials (Minsk, Belarus), <https://www.scopus.com/authid/detail.uri?authorId=7004624845>

CATALIN Stefan, PhD, Associate Professor, Technical University of Dresden (Dresden, Germany), <https://www.scopus.com/authid/detail.uri?authorId=35203904500>; <https://www.webofscience.com/wos/author/record/1309251>

JAY Sagin, PhD, Associate Professor, Nazarbayev University (Astana, Kazakhstan), <https://www.scopus.com/authid/detail.uri?authorId=57204467637>; <https://www.webofscience.com/wos/author/record/907886>

FRATTINI Paolo, PhD, Associate Professor, University of Milano - Bicocca (Milan, Italy), <https://www.scopus.com/authid/detail.uri?authorId=56538922400>

NURPEISOVA Marzhan Baysanovna, Doctor of Technical Sciences, Professor of Satbayev University (Almaty, Kazakhstan), <https://www.scopus.com/authid/detail.uri?authorId=57202218883>; <https://www.webofscience.com/wos/author/record/AAD-1173-2019>

RATOV Boranbay Tovbasarovich, Doctor of Technical Sciences, Professor, Head of the Department of Geophysics and Seismology, Satbayev University (Almaty, Kazakhstan), <https://www.scopus.com/authid/detail.uri?authorId=55927684100>; <https://www.webofscience.com/wos/author/record/1993614>

RONNY Berndtsson, Professor, Director of the Centre for Advanced Middle Eastern Studies, Lund University (Lund, Sweden), <https://www.scopus.com/authid/detail.uri?authorId=7005388716>; <https://www.webofscience.com/wos/author/record/1324908>

MIRLAS Vladimir, PhD, Professor, Eastern R&D Center, Ariel University (Ariel, Israel), <https://www.scopus.com/authid/detail.uri?authorId=8610969300>; <https://www.webofscience.com/wos/author/record/53680261>

News of the National Academy of Sciences of the Republic of Kazakhstan. Series of geology and technology sciences.

ISSN 2518-170X (Online),

ISSN 2224-5278 (Print)

Owner: «Central Asian Academic Research Center» LLP (Almaty).

The certificate of registration of a periodical printed publication in the Committee of information of the Ministry of Information and Communications of the Republic of Kazakhstan № KZ50VPY00121155, issued on 05.06.2025
Thematic scope: *geology, hydrogeology, geography, mining and chemical technologies of oil, gas and metals*
Periodicity: 6 times a year.

<http://www.geology-technical.kz/index.php/en/>

© «Central Asian Academic Research Center» LLP, 2026.

БАС РЕДАКТОР

ЖУРЫНОВ Мұрат Жұрыңұлы, химия ғылымдарының докторы, профессор, ХҒАҚ және ҚР ҰҒА академигі, Мұнай өңдеу және мұнай-химиясы ғылыми-зерттеу институтының бас директоры (Алматы, Қазақстан), <https://www.scopus.com/authid/detail.uri?authorId=6602177960>; <https://www.webofscience.com/wos/author/record/2017489>

БАС РЕДАКТОРДЫҢ ОРЫНБАСАРЫ:

АБСАДЫҚОВ Бақыт Нәрікбайұлы, техника ғылымдарының докторы, профессор, ҚР ҰҒА академигі, Қ.И. Сәтбаев атындағы Қазақ ұлттық техникалық зерттеу университеті (Алматы, Қазақстан), <https://www.scopus.com/authid/detail.uri?authorId=6504694468>; <https://www.webofscience.com/wos/author/record/2411827>

РЕДАКЦИЯ АЛҚАСЫ:

ӘБСӘМЕТОВ Мәліс Құдысұлы, геология-минералогия ғылымдарының докторы, профессор, ҚР ҰҒА академигі, У.М. Ахмедсафин атындағы Гидрогеология және геоэкология институтының директоры (Алматы, Қазақстан), <https://www.scopus.com/authid/detail.uri?authorId=56955769200>; <https://www.webofscience.com/wos/author/record/1937883>

ЖОЛТАЕВ Герой Жолтайұлы, геология-минералогия ғылымдарының докторы, профессор, ҚР ҰҒА құрметті академигі (Алматы, Қазақстан), <https://www.scopus.com/authid/detail.uri?authorId=57112610200>; <https://www.webofscience.com/wos/author/record/1939201>

СНОУ Дэниел, PhD, қауымдастырылған профессор, Небраска университетінің Су ғылымдары зертханасының директоры (Небраска, АҚШ), <https://www.scopus.com/authid/detail.uri?authorId=7103259215>; <https://www.webofscience.com/wos/author/record/1429613>

ЗЕЛЪТМАНН Раймар, PhD, Жер туралы ғылымдар бөлімінің петрология және пайдалы қазбалар кен орындары саласындағы зерттеулерінің жетекшісі, Табиғи тарих мұражайы (Лондон, Ұлыбритания), <https://www.scopus.com/authid/detail.uri?authorId=55883084800>; <https://www.webofscience.com/wos/author/record/1048681>

ПАНФИЛОВ Михаил Борисович, техника ғылымдарының докторы, Нанси университетінің профессоры (Нанси, Франция), <https://www.scopus.com/authid/detail.uri?authorId=7003436752>; <https://www.webofscience.com/wos/author/record/1230499>

ШЕН Пин, PhD, Қытай геологиялық қоғамының Тау-кен геологиясы комитеті директорының орынбасары, Американдық экономикалық геологтар қауымдастығының мүшесі (Бейжің, Қытай), <https://www.scopus.com/authid/detail.uri?authorId=57202873965>; <https://www.webofscience.com/wos/author/record/1753209>

ФИШЕР Аксель, PhD, қауымдастырылған профессор, Дрезден техникалық университеті (Дрезден, Германия), <https://www.scopus.com/authid/detail.uri?authorId=35738572100>; <https://www.webofscience.com/wos/author/record/2085986>

АГАБЕКОВ Владимир Енокович, химия ғылымдарының докторы, Беларусь ҰҒА академигі, Жаңа материалдар химиясы институтының құрметті директоры (Минск, Беларусь), <https://www.scopus.com/authid/detail.uri?authorId=7004624845>

КАТАЛИН Стефан, PhD, қауымдастырылған профессор, Дрезден Техникалық университеті (Дрезден, Германия), <https://www.scopus.com/authid/detail.uri?authorId=35203904500>; <https://www.webofscience.com/wos/author/record/1309251>

САҒЫНТАЕВ Жанай, PhD, қауымдастырылған профессор, Назарбаев университеті (Астана, Қазақстан), <https://www.scopus.com/authid/detail.uri?authorId=57204467637>; <https://www.webofscience.com/wos/author/record/907886>

ФРАТТИНИ Паоло, PhD, қауымдастырылған профессор, Бикокок Милан университеті (Милан, Италия), <https://www.scopus.com/authid/detail.uri?authorId=56538922400>

НҮРПЕЙСОВА Маржан Байсанқызы, техника ғылымдарының докторы, Қ.И. Сәтбаев атындағы Қазақ ұлттық техникалық зерттеу университетінің профессоры (Алматы, Қазақстан), <https://www.scopus.com/authid/detail.uri?authorId=57202218883>; <https://www.webofscience.com/wos/author/record/AAD-1173-2019>

РАТОВ Боранбай Товбасарович, техника ғылымдарының докторы, профессор, «Геофизика және сейсмология» кафедрасының меңгерушісі, Қ.И. Сәтбаев атындағы Қазақ ұлттық техникалық зерттеу университеті (Алматы, Қазақстан), <https://www.scopus.com/authid/detail.uri?authorId=55927684100>; <https://www.webofscience.com/wos/author/record/1993614>

РОННИ Бердтссон, профессор, Таяу Шығысты заманауи зерттеу орталығының директоры, Лунд университеті (Лунд, Швеция), <https://www.scopus.com/authid/detail.uri?authorId=7005388716>; <https://www.webofscience.com/wos/author/record/1324908>

МИРІАС Владимир, PhD, профессор, Ариэль университетінің Шығыс ғылыми-зерттеу орталығы (Ариэль, Израиль), <https://www.scopus.com/authid/detail.uri?authorId=8610969300>; <https://www.webofscience.com/wos/author/record/53680261>

News of the National Academy of Sciences of the Republic of Kazakhstan. Series of geology and technology sciences.

ISSN 2518-170X (Online),

ISSN 2224-5278 (Print)

Меншіктеуші: «Орталық Азия академиялық ғылыми орталығы» ЖШС (Алматы қ.).

Қазақстан Республикасының Ақпарат және коммуникациялар министрлігінің Ақпарат комитетінде 05.06.2025 ж. берілген № KZ50VPY00121155 мерзімдік басылым тіркеуіне қойылу туралы куәлік. Тақырыптық бағыты: *геология, гидрогеология, география, тау-кен ісі, мұнай, газ және металдардың химиялық технологиялары*

Мерзімділігі: жылына 6 рет.

<http://www.geolog-technical.kz/index.php/en/>

ГЛАВНЫЙ РЕДАКТОР

ЖУРИНОВ Мурат Журнинович, доктор химических наук, профессор, академик МАН и НАН РК, Генеральный директор НИИ нефтепереработки и нефтехимии (Алматы, Казахстан), <https://www.scopus.com/authid/detail.uri?authorId=6602177960>; <https://www.webofscience.com/wos/author/record/2017489>

ЗАМЕСТИТЕЛЬ ГЛАВНОГО РЕДАКТОРА

АБСАДЫКОВ Бахыт Нарикбаевич, доктор технических наук, профессор, академик НАН РК, Казахский национальный исследовательский технический университет им. К.И. Сатпаева (Алматы, Казахстан), <https://www.scopus.com/authid/detail.uri?authorId=6504694468>; <https://www.webofscience.com/wos/author/record/2411827>

РЕДАКЦИОННАЯ КОЛЛЕГИЯ:

АБСАМЕТОВ Малис Кудысович, доктор геолого-минералогических наук, профессор, академик НАН РК, директор Института гидрогеологии и геоэкологии им. У.М. Ахмедсафина (Алматы, Казахстан), <https://www.scopus.com/authid/detail.uri?authorId=56955769200>; <https://www.webofscience.com/wos/author/record/1937883>

ЖОЛТАЕВ Герой Жолтаевич, доктор геолого-минералогических наук, профессор, почетный академик НАН РК (Алматы, Казахстан), <https://www.scopus.com/authid/detail.uri?authorId=57112610200>; <https://www.webofscience.com/wos/author/record/1939201>

СНОУ Дэниел, PhD, ассоциированный профессор, директор Лаборатории водных наук Университета Небраски (Небраска, США), <https://www.scopus.com/authid/detail.uri?authorId=7103259215>; <https://www.webofscience.com/wos/author/record/1429613>

ЗЕЛЬТМАНН Раймар, PhD, руководитель исследований в области петрологии и месторождений полезных ископаемых в Отделе наук о Земле Музея естественной истории (Лондон, Великобритания), <https://www.scopus.com/authid/detail.uri?authorId=55883084800>; <https://www.webofscience.com/wos/author/record/1048681>

ПАНФИЛОВ Михаил Борисович, доктор технических наук, профессор Университета Нанси (Нанси, Франция), <https://www.scopus.com/authid/detail.uri?authorId=7003436752>; <https://www.webofscience.com/wos/author/record/1230499>

ШЕН Пин, PhD, заместитель директора Комитета по горной геологии Китайского геологического общества, член Американской ассоциации экономических геологов (Пекин, Китай), <https://www.scopus.com/authid/detail.uri?authorId=57202873965>; <https://www.webofscience.com/wos/author/record/1753209>

ФИШЕР Аксель, PhD, ассоциированный профессор, Технический университет Дрезден (Дрезден, Берлин), <https://www.scopus.com/authid/detail.uri?authorId=35738572100>; <https://www.webofscience.com/wos/author/record/2085986>

АГАБЕКОВ Владимир Еноквич, доктор химических наук, академик НАН Беларуси, почетный директор Института химии новых материалов (Минск, Беларусь), <https://www.scopus.com/authid/detail.uri?authorId=7004624845>

КАТАЛИН Стефан, PhD, ассоциированный профессор, Технический университет Дрезден (Дрезден, Германия), <https://www.scopus.com/authid/detail.uri?authorId=35203904500>; <https://www.webofscience.com/wos/author/record/1309251>

САГИНТАЕВ Жанай, PhD, ассоциированный профессор, Назарбаев университет (Астана, Казахстан), <https://www.scopus.com/authid/detail.uri?authorId=57204467637>; <https://www.webofscience.com/wos/author/record/907886>

ФРАТТИНИ Паоло, PhD, ассоциированный профессор, Миланский университет Бикокк (Милан, Италия), <https://www.scopus.com/authid/detail.uri?authorId=56538922400>

НУРПЕИСОВА Маржан Байсановна, доктор технических наук, профессор Казахского национального исследовательского технического университета им. К.И. Сатпаева (Алматы, Казахстан), <https://www.scopus.com/authid/detail.uri?authorId=57202218883>; <https://www.webofscience.com/wos/author/record/AAD-1173-2019>

РАТОВ Боранбай Товбасарович, доктор технических наук, профессор, заведующий кафедрой «Геофизика и сейсмология», Казахский национальный исследовательский технический университет им. К.И. Сатпаева (Алматы, Казахстан), <https://www.scopus.com/authid/detail.uri?authorId=55927684100>; <https://www.webofscience.com/wos/author/record/1993614>

РОННИ Бердтссон, профессор, Директор Центра современных ближневосточных исследований, Лундский университет (Лунд, Швеция), <https://www.scopus.com/authid/detail.uri?authorId=7005388716>; <https://www.webofscience.com/wos/author/record/1324908>

МИРЛАС Владимир, PhD, профессор, Восточный научно-исследовательский центр, Университет Ариэля (Ариэль, Израиль), <https://www.scopus.com/authid/detail.uri?authorId=8610969300>; <https://www.webofscience.com/wos/author/record/53680261>

News of the National Academy of Sciences of the Republic of Kazakhstan. Series of geology and technology sciences.

ISSN 2518-170X (Online),

ISSN 2224-5278 (Print)

Собственник: ТОО «Центрально-Азиатский академический научный центр» (г. Алматы).

Свидетельство о постановке на учет периодического печатного издания в Комитете информации Министерства информации и коммуникаций и Республики Казахстан № KZ50VPY00121155, выданное 05.06.2025 г.

Тематическая направленность: *геология, гидрогеология, география, горное дело и химические технологии нефти, газа и металлов*

Периодичность: 6 раз в год.

<http://www.geolog-technical.kz/index.php/en/>

CONTENTS

Abetov A.E., Seitzhanov A.K., Samenov Y.R., Zhassymbek S.A. Machine learning and neural networks for lithofacies mapping and reservoir property evaluation of core samples.....	8
Aitkaliyev A.K., Pak Y.N., Kolmakov Y.V., Pak D.Y., Matishev T.V. Application of the X-Ray radiometric method to improve the operational quality control of copper ores during geological testing.....	26
Altay Y.A., Karymsakova N.T., Fedorov A.V., Absadykov D.B., Ismagul G.K. Predictive control of diagnostically significant parameters of acoustic emission using machine learning: new data.....	41
Astanakulov K.D., Kodirova M.G., Saydumarov B., Nersesyan D.V., Kurashkin S.O. Resource potential of ecological and geological systems of allocated soil masses.....	58
Avazov Sh.B., Yodgorov Sh.I., Mukhammadkulov N.M., Aktamov B.U., Khayriddinov B.B. Instrumental seismometric assessment of the impact of technogenic seismic vibrations on the structural stability of historical objects.....	74
Baskanbayeva D., Kalmaganbetov S., Sabirova L., Zholdybayeva G., Koptleuov K. CFD analysis of screw compressor rotor geometry influence on gas compression efficiency in geology.....	92
Borotov A.N., Karshiev F.U., Igamberdiyev A.A., Grigoryan A.G., Sarigo N.V. Ecological aspects of resource conservation in the development of mineral deposits.....	107
Gerasidi V.V., Lisachenko A.V., Apatenko A.S., Sevryugina N.S., Fomin A.Y. Analysis of the application of non-destructive testing methods for assessing the technical condition of mining equipment motors based on vibration parameters.....	121
Hajiyeva A.Z., Ibrahimova L.P., Humbatova Sh.Y., Jafarova F.M. Ecological processes of vertical landscape transformation and their manifestation in the natural landscapes of Nakhchivan.....	135
Jakiyayev D.K., Nussipali R.K.*, Malibekov A.K., Jakiyayev B.D., Zhashen S.Zh. Statistical model of multi-cycle fatigue of steel structural elements under a complex non-uniform stress state.....	149
Jumatov Y.K., Tashbulatov S.B., Pushanov A.N., Kozenkova G.L., Yarygina I.V. Technological substantiation of sustainable mining reclamation of disturbed lands in open pit operations.....	169
Kainenova T.S., Kosmbaeva G.T., Bissembayeva K.T., Otarbayeva A.T., Orazbek A.A. Effectiveness of measures to regulate the development process at the Alibekmola field.....	185

Koishiyeva G.Zh., Yerimova A.Zh., Kurbaniyazov S.K., Agaidarova K.H., Abdraimova K.T.	
Radiological properties and stratigraphic significance of glauconite-bearing formations: implications for paleoenvironments and geochemical zonation.....	203
Kondratiev V.V., Bryukhanova N.N., Kononenko R.V., Gladkikh V.A., Matasova I.Y.	
Environmental and technological assessment of beneficiation tailings reprocessing based on mechanical activation and non-ferrous metals leaching.....	223
Kuldeyev Ye., Negmatov S., Nurpeissova M., Kirgizbaeva D., Donenbayeva N.	
Geodynamic Polygon of the Zhilandy Ore Field: Results and Prospects.....	237
Madibekov A., Christian Opp., Karimov A., Ismukhanova L., Zhadi A.	
Regularities of distribution and accumulation factors of heavy metals in soils of the Zhetysu region (Kazakhstan).....	253
Malikov G.I., Musayeva S.A., Mammadov K.S., Jabiyeva U.M., Jafarova K.V.	
Effects of hydrocarbon fuel quality fluctuations on energy generation efficiency, economic viability, and environmental footprint.....	272
Narbaev M.T., Ismailova G.K., Narbaeva K.T., Burlibayeva D.M., Groll M.	
Assessment of ecological and water management parameters of the Syrdarya River.....	290
Nurmagambetov A.	
On seismic hazard of Almaty and tectonic faults in the city.....	309
Permana A.P., Kasim M., Hutagalung R., Uno D.A.N., Sandi I.N.	
petrographic, provenance, and tectonic setting of Dolokapa formation sandstone, North Gorontalo.....	319
Ratov B.T., Khomenko V.L., Yavorska O.O., Koroviaka Ye.A., Akhmetova N.S.	
Analytical and structural justification of a wellhead sealing device for large-diameter drilling operations.....	335
Skrobala V.M., Popovych V.V., Kopylov V.P., Popovych N.P.	
Comprehensive assessment of heavy metal pollution of a river within a large city.....	355
Sunakbaeva D.Kh., Yuldashbek D.Kh., Aitekova K., Seitbayev K.Zh.	
Monitoring heavy metals in soils and waters of the City of Turkestan: geoecological aspect.....	371
Zakirov M.M., Agzamova I.A., Ochilov G.E., Gulyamov G.D., Xudayberdiyev T.M.	
Analysis of the results of changes in the gas and isotopic composition of groundwater during the period of earthquake preparation.....	385
Zhanbatyrov A.A., Tukhfatov Zh.K., Bektay E.K., Turisbekova G.S., Zhanbatyrov N.A.	
Current state of potash ore development in the Caspian lowlands of the Republic of Kazakhstan: problems and solutions.....	309

NEWS OF THE NATIONAL ACADEMY OF SCIENCES OF THE REPUBLIC
OF KAZAKHSTAN, SERIES OF GEOLOGY AND TECHNICAL SCIENCES
ISSN 2224-5278
Volume 2.
Number 476 (2026), 92–106

<https://doi.org/10.32014/2026.2518-170X.617>

UDC: 550.8.07
IRSTI: 38.59.21

©**Baskanbayeva D.¹, Kalmaganbetov S.^{1*}, Sabirova L.¹, Zholdybayeva G.²,
Koptleuov K.¹, 2026.**

¹Satbayev University, Almaty, Kazakhstan;

²Abylkas Saginov Karaganda Technical University, Karaganda, Kazakhstan.

E-mail: s.kalmaganbetov@satbayev.university

CFD ANALYSIS OF SCREW COMPRESSOR ROTOR GEOMETRY INFLUENCE ON GAS COMPRESSION EFFICIENCY IN GEOLOGY

Baskanbayeva Dinara — PhD, Satbayev University, Almaty, Kazakhstan,

E-mail: d.baskanbayeva@satbayev.university, <https://orcid.org/0000-0003-1688-0666>;

Kalmaganbetov Sanzhar — PhD, Satbayev University, Almaty, Kazakhstan,

E-mail: s.kalmaganbetov@satbayev.university, <https://orcid.org/0009-0001-9248-4086>;

Sabirova Leyla — Candidate of Technical Sciences, Associate Professor, Satbayev University, Almaty, Kazakhstan,

E-mail: l.sabirova@satbayev.university, <https://orcid.org/0000-0001-8231-9944>;

Zholdybayeva Gulnar — Candidate of Technical Sciences, Assistant Professor, Abylkas Saginov Karaganda Technical University, Karaganda, Kazakhstan,

E-mail: goldybaeva@mail.ru, <https://orcid.org/0000-0002-6768-5580>;

Koptleuov Kanat — Master Student, Institute of Energy and Mechanical Engineering, Satbayev University, Almaty, Kazakhstan,

E-mail: m.saulet@satbayev.university, <https://orcid.org/0009-0003-0941-1666>.

Abstract. *Relevance.* compressor systems play a critical role in the oil, gas, and mining industries, ensuring the transportation and compression of technological gases as well as supporting extraction, processing, and ventilation operations. The performance and energy efficiency of such systems are fundamentally governed by the rotor geometry of the compressor, which directly determines the internal flow structure, pressure distribution, and the magnitude of hydrodynamic losses. While twin-screw compressors have been extensively studied in the scientific literature, the optimization of rotor geometry for three-screw compressor configurations remains insufficiently investigated, despite their practical advantages in terms of torque balance and smoother pressure delivery. *Objective.* to perform a comparative analysis of two rotor geometries for a three-screw compressor using integrated CAD/CAE modeling and computational fluid dynamics (CFD). Parametric three-dimensional rotor models were developed in SolidWorks for

two configurations: a conventional baseline profile (Type A) and an analytically optimized profile based on the Stosic formulation (Type B). *Methods.* Numerical simulations of compressible turbulent gas flow were conducted using the Flow Simulation module, employing the Favre-averaged Navier–Stokes equations coupled with the energy conservation equation and the k– ϵ turbulence closure model. The analysis encompassed velocity field distribution, static pressure distribution, vortex formation intensity, and pressure pulsation amplitude within the compressor working chamber. *Results.* demonstrate that rotor geometry exerts a decisive influence on the flow structure and energy characteristics of the compression process. Type A exhibits pronounced non-uniformity of velocity and pressure fields, intensified vortex activity, and localized pressure peaks indicative of elevated aerodynamic losses. In contrast, the Type B Stosic profile produces a more uniform pressure distribution, reduced pressure pulsation amplitude, and a more stable compression regime, consistent with its analytically optimized inter-lobe geometry. *The practical significance of this research* lies in the validation of a CAD/CAE methodology for the optimization of rotor geometry and the design of energy-efficient three-screw compressors for industrial gas compression systems in the oil, gas, and mining sectors.

Keywords: three-screw compressor, CFD simulation, rotor geometry, pressure distribution, vortex structures, CAD/CAE modeling

Funding. *This research was conducted as part of the targeted funding program for the project IRN BR24992956-OT-24, titled “Development and creation of innovative equipment and technologies for gas compression”.*

For citations: *Baskanbayeva D., Kalmaganbetov S., Sabirova L., Zholdybayeva G., Koptleuov K. CFD Analysis of Screw Compressor Rotor Geometry Influence on Gas Compression Efficiency in Geology. News of the National Academy of Sciences of the Republic of Kazakhstan, Series of Geology and Technical Sciences. 2026. No.2. Pp. 92–106. DOI: <https://doi.org/10.32014/2026.2518-170X.617>*

©Басқанбаева Д.¹, Калмаганбетов С.^{1*}, Сабирова Л.¹, Жолдыбаева Г.²,
Көптлеуов Қ.¹, 2026.

¹Сәтбаев университеті, Алматы, Қазақстан;

²Әбілқас Сағынов атындағы Қарағанды техникалық университеті,
Қарағанды, Қазақстан.

E-mail: s.kalmaganbetov@satbayev.university

ГЕОЛОГИЯДА ГАЗ СЫҒУ ТИІМДІЛІГІНЕ ВИНТТІ КОМПРЕССОР РОТОРЛАРЫ ГЕОМЕТРИЯСЫНЫҢ CFD ТАЛДАУЫ

Басқанбаева Динара — PhD, Сәтбаев университеті, Алматы, Қазақстан,
E-mail: d.baskanbayeva@satbayev.university, <https://orcid.org/0000-0003-1688-0666>;

Калмаганбетов Санжар — PhD, Сәтбаев университеті, Алматы, Қазақстан,
E-mail: s.kalmaganbetov@satbayev.university, <https://orcid.org/0009-0001-9248-4086>;

Сабирова Лейла — техника ғылымдарының кандидаты, қауымдастырылған профессор,
Сәтбаев университеті, Алматы, Қазақстан,
E-mail: l.sabirova@satbayev.university, <https://orcid.org/0000-0001-8231-9944>;

Жолдыбаева Гүлнар — техника ғылымдарының кандидаты, ассистент профессор, Әбілқас
Сағынов атындағы Қарағанды техникалық университеті, Қарағанды, Қазақстан,
E-mail: goldybaeva@mail.ru, <https://orcid.org/0000-0002-6768-5580>;

Көптлеуов Қанат — магистрант, Энергетика және машина жасау институты, Сәтбаев
университеті, Алматы, Қазақстан,
E-mail: m.saulet@satbayev.university, <https://orcid.org/0009-0003-0941-1666>.

Аннотация. *Өзектілігі.* компрессорлық жүйелер мұнай, газ және тау-кен өнеркәсібінде технологиялық газдарды тасымалдау мен сығымдауды қамтамасыз ете отырып, сондай-ақ өндіру, өңдеу және желдету процестерін қолдай отырып, маңызды рөл атқарады. Екі бұрандалы компрессорлар кеңінен қолданысқа енгенімен, үш бұрандалы конфигурациялар үшін ротор геометриясын оңтайландыру бұрандалы момент теңгерімі мен қысымды біркелкі беру тұрғысындағы практикалық артықшылықтарына қарамастан, әлі жеткілікті зерттелмеген сала болып қала береді. *Жұмыстың мақсаты.* интегрирленген CAD/CAE-модельдеу мен есептеу гидрогаздинамикасын (CFD) қолдана отырып, үш бұрандалы компрессордың екі ротор геометриясына салыстырмалы талдау жүргізу болып табылады. Роторлардың параметрлік үш өлшемді модельдері SolidWorks ортасында екі конфигурация үшін әзірленді: стандартты базалық профиль (А Түрі) және Stosic формулировкасына негізделген аналитикалық тұрғыдан оңтайландырылған профиль (В Түрі). *Пайдаланылған әдістер.* сығылатын турбуленттік газ ағынының сандық модельдеуі Flow Simulation модулінде Фавр бойынша орташаланған Навье–Стокс теңдеулері, энергияны сақтау теңдеуі және k–ε турбуленттілік моделі пайдаланыла отырып жүргізілді. Талдау компрессордың жұмыс камерасындағы жылдамдық өрісінің таралуын, статикалық қысымның таралуын, вихрь түзілуінің қарқындылығын және қысым пульсациясының амплитудасын қамтыды. *Нәтижелері.* ротор геометриясының сығымдау процесінің ағын құрылымы мен энергетикалық сипаттамаларына шешуші әсер ететінін көрсетеді. А Түрі жылдамдық пен қысым өрістерінің айқын біркелкі еместігін, күшейтілген вихрьлік белсенділікті және жоғары аэродинамикалық шығындарды көрсететін жергілікті шындық қысым мәндерін байқатады. Stosic профилі (В Түрі), керісінше, қысымның біркелкі таралуын, қысым пульсациясының төмендетілген амплитудасын және аналитикалық тұрғыдан оңтайландырылған қалақаралық саңылау геометриясымен үйлесімді тұрақты сығымдау режимін қамтамасыз етеді. *Зерттеудің практикалық маңыздылығы.* Мұнай, газ және тау-кен өнеркәсібіндегі өнеркәсіптік газ компрессорлық жүйелеріне арналған энергия тиімді үш бұрандалы компрессорларды жобалау мен ротор геометриясын

оңтайландыруға арналған CAD/CAE-әдіснамасын апробациялауда болып табылады.

Түйін сөздер: үшвинтті компрессор, CFD модельдеу, ротор геометриясы, қысым таралуы, құйын құрылымдары, CAD/CAE талдау

©Басқанбаева Д.¹, Калмаганбетов С.^{1*}, Сабирова Л.¹, Жолдыбаева Г.²,
Көптлеуов К.¹, 2026.

¹Сатпаев университет, Алматы, Қазақстан;

²Карагандинский технический университет имени Абылкаса Сагинова,
Караганда, Қазақстан.

E-mail: s.kalmaganbetov@satbayev.university

CFD-АНАЛИЗ ВЛИЯНИЯ ГЕОМЕТРИИ РОТОРОВ ВИНТОВЫХ КОМПРЕССОРОВ НА ЭФФЕКТИВНОСТЬ ГАЗОКОМПРЕССИИ В ГЕОЛОГИИ

Басқанбаева Динара — PhD, Сатпаев университет, Алматы, Қазақстан,

E-mail: d.baskanbayeva@satbayev.university, <https://orcid.org/0000-0003-1688-0666>;

Калмаганбетов Санжар — PhD, Сатпаев Университет, Алматы, Қазақстан,

E-mail: s.kalmaganbetov@satbayev.university, <https://orcid.org/0009-0001-9248-4086>;

Сабирова Лейла — кандидат технических наук, ассоциированный профессор, Сатпаев университет, Алматы, Қазақстан,

E-mail: l.sabirova@satbayev.university, <https://orcid.org/0000-0001-8231-9944>;

Жолдыбаева Гульнар — кандидат технических наук, ассистент профессор, Карагандинский технический университет имени Абылкаса Сагинова, Караганда, Қазақстан,

E-mail: goldybaeva@mail.ru, <https://orcid.org/0000-0002-6768-5580>;

Көптлеуов Канат — магистрант, Институт энергетики и машиностроения, Сатпаев университет, Алматы, Қазақстан,

E-mail: m.saulet@satbayev.university, <https://orcid.org/0009-0003-0941-1666>.

Аннотация. *Актуальность.* Компрессорные системы играют ключевую роль в нефтяной, газовой и горнодобывающей промышленности, обеспечивая транспортировку и сжатие технологических газов, а также поддерживая процессы добычи, переработки и вентиляции. Несмотря на широкое распространение двухвинтовых компрессоров, оптимизация геометрии ротора для трёхвинтовых конфигураций остаётся недостаточно изученной областью, несмотря на их практические преимущества, включая балансировку крутящего момента и более плавную подачу давления. *Цель исследования* - проведение сравнительного анализа двух геометрий роторов трёхвинтового компрессора с применением интегрированного CAD/CAE-моделирования и методов вычислительной гидрогазодинамики (CFD). *Методы.* Параметрические трёхмерные модели роторов были разработаны в среде SolidWorks для двух конфигураций: стандартного базового профиля (тип А) и аналитически оптимизированного профиля на основе формулировки Stosic (тип В). Численное моделирование сжимаемого турбулентного течения

газа выполнялось в модуле Flow Simulation с использованием осреднённых по Фавру уравнений Навье–Стокса совместно с уравнением сохранения энергии и моделью турбулентности k – ϵ . Анализ охватывал распределение полей скоростей и статического давления, интенсивность вихреобразования и амплитуду пульсаций давления в рабочей камере компрессора. *Результаты.* Полученные данные показывают, что геометрия ротора оказывает определяющее влияние на структуру течения и энергетические характеристики процесса сжатия. Конфигурация типа А характеризуется выраженной неравномерностью полей скоростей и давлений, повышенной вихревой активностью и локальными пиковыми значениями давления, что свидетельствует о росте аэродинамических потерь. Профиль Stosic (тип В), напротив, обеспечивает более равномерное распределение давления, снижение амплитуды пульсаций и более стабильный режим сжатия, что соответствует его аналитически оптимизированной геометрии межлопастных зазоров. *Практическая значимость.* Результаты исследования подтверждают эффективность применения CAD/CAE-методологии для оптимизации геометрии роторов и проектирования энергоэффективных трёхвинтовых компрессоров, предназначенных для промышленных газокomppressorных систем нефтяной, газовой и горнодобывающей отраслей.

Ключевые слова: трёхвинтовой компрессор, CFD-моделирование, геометрия ротора, распределение давления, вихревые структуры, CAD/CAE анализ

Introduction. Screw compressors are widely used in refrigeration, energy conversion, and industrial gas-handling systems due to their high volumetric efficiency, continuous compression process, and relatively low vibration levels. Increasing global demand for energy-efficient technologies has intensified research aimed at improving compressor performance through advanced rotor geometry design and optimization. Recent reviews emphasize that compressed air systems represent a significant share of industrial energy consumption, highlighting the importance of reducing internal losses and improving flow stability through improved rotor profiles and clearance control (Li et al., 2025). In this context, the geometric configuration of screw rotors plays a crucial role in determining pressure evolution, leakage mechanisms, and hydrodynamic efficiency.

The development of modern CAD/CAE tools and high-fidelity computational fluid dynamics (CFD) has fundamentally changed the design workflow of screw compressors. Numerical simulations enable detailed analysis of transient compressible flow, vortex structures, and pressure distribution inside rotating working chambers, providing valuable insight into performance limitations before experimental validation. Several recent studies demonstrated that rotor parameters such as helix angle, wrap angle, and groove depth significantly influence internal flow behaviour and energy efficiency (Tsao et al., 2023; Aydın et al., 2025).

Furthermore, CAD-driven optimization combined with CFD has proven effective for identifying design modifications that reduce specific power consumption and improve volumetric efficiency (Brinas et al., 2025). Multiphase modelling approaches have also been applied to oil-injected screw compressors, revealing the importance of accurately representing fluid–structure interaction and phase distribution within the working chamber (Basha et al., 2019).

Despite the extensive body of research devoted to twin-screw compressors, investigations focused on three-screw configurations remain comparatively limited. The three-screw architecture, consisting of one central rotor and two auxiliary rotors, offers potential advantages in load balancing and smoother torque transmission but introduces more complex internal flow interactions and pressure redistribution phenomena. Previous studies have shown that rotor clearances and geometric alignment strongly affect performance and durability in multi-rotor machines (Buckney et al., 2017). In addition, recent work on rotor profile reconstruction highlighted the geometric complexity involved in designing accurate three-screw compressor rotors (Baroiu et al., 2022), while investigations of pressure pulsations revealed that multi-rotor systems may exhibit intensified unsteady flow behaviour under certain operating conditions (Wang et al., 2025). Emerging studies on advanced screw machine geometries further indicate that even small variations in rotor shape can significantly alter flow stability and hydrodynamic losses (Lacevic et al., 2026).

Consequently, a clear research gap exists in comprehensive comparative investigations of rotor geometries for three-screw compressors using integrated CAD/CAE and CFD approaches. Most recent studies focus primarily on twin-screw systems or analyze individual parameters without evaluating alternative rotor geometries under identical boundary conditions. Addressing this gap is essential for developing next-generation high-efficiency compressor systems.

Therefore, the objective of the present study is to perform a CAD/CAE-based comparative analysis of two rotor geometries in a three-screw compressor. The research focuses on evaluating internal flow structure, vortex formation, and pressure distribution in order to identify geometric features that contribute to improved hydrodynamic stability and reduced energy losses. The obtained results are expected to support the optimization of rotor design and enhance the development of energy-efficient screw compressor technologies.

Materials and methods. Two different rotor geometries of a three-screw compressor were developed (Figure 1) and investigated in this study, hereafter referred to as Geometry A and Geometry B. The geometrical models were created using a parametric CAD approach in SolidWorks, enabling precise control of helix angle, rotor diameter, lead, and inter-axial distance. Parametric modelling allows rapid modification of profile parameters and facilitates comparative evaluation under identical operating conditions. Previous research has shown that accurate geometric representation of screw rotors is essential for reliable CFD prediction

because small deviations in profile shape may significantly influence leakage paths and pressure evolution (Ziviani et al., 2018; Kovacevic & Stosic, 2019).

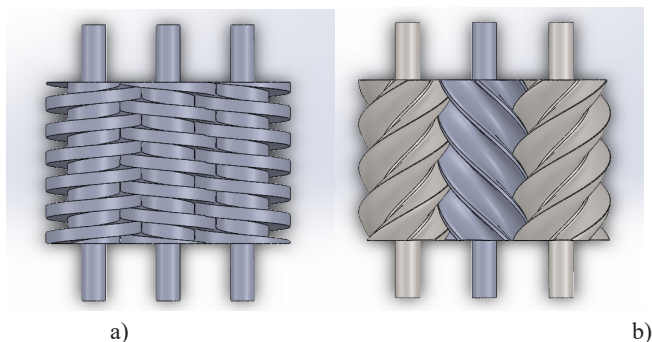

Figure 1. (a) Rotor profile of Type A (b) Rotor profile of Type B.

The computational domain included the internal working chamber formed by the central rotor and two auxiliary rotors. To simplify numerical analysis while maintaining physical relevance, clearances between rotors and casing were assumed constant along the axial direction. The rotor positions were fixed for quasi-steady analysis of internal flow fields, a commonly adopted approach in preliminary compressor investigations (Liu et al., 2017).

Numerical simulations of the internal flow were performed using the SolidWorks Flow Simulation module. The governing equations include the conservation of mass, momentum, and energy for compressible turbulent flow. The Reynolds-averaged Navier–Stokes (RANS) formulation was applied, which is widely used in screw compressor CFD studies due to its balance between computational cost and accuracy (Papes et al., 2016; Vande Voorde et al., 2020). Turbulence effects were represented using a two-equation model suitable for rotating internal flows with moderate Reynolds numbers.

Results and discussions. Air was selected as the working fluid and modelled as a compressible Newtonian gas. The numerical simulations were performed under steady-state conditions with turbulence effects included. The flow field inside the three-screw compressor was described using the fundamental conservation equations of continuum mechanics commonly applied in the analysis of compressible viscous flows.

The conservation of mass in the computational domain is expressed by the steady compressible continuity equation:

$$\nabla \cdot (\rho \vec{v}) = 0, \quad (1)$$

which ensures mass balance within the working chamber and represents the standard formulation for compressible CFD simulations of rotary machines. The momentum transport in the flow was governed by the Navier–Stokes equations:

$$\rho(\vec{v} \cdot \nabla)\vec{v} = -\nabla p + \mu\nabla^2\vec{v}, \quad (2)$$

where pressure gradients and viscous stresses determine the dynamic equilibrium of the gas flow. These equations constitute the core framework of modern CFD models applied to screw compressors and other positive-displacement machines.

The thermal state of the working medium was described using the energy conservation equation:

$$\rho c_p(\vec{v} \cdot \nabla T) = k\nabla^2 T + \Phi, \quad (3)$$

where the term Φ represents viscous dissipation, accounting for irreversible energy losses associated with turbulent motion and shear stresses. Such a formulation is widely adopted for the numerical investigation of compressible turbulent flows in rotating machinery.

The velocity vector inside the working chamber was defined as

$$\vec{v} = (u, v, w), \quad (4)$$

and its magnitude was evaluated using the Euclidean norm

$$|\vec{v}| = \sqrt{u^2 + v^2 + w^2}. \quad (5)$$

Spatial variations of velocity were characterized by the convective acceleration term

$$\vec{a} = (\vec{v} \cdot \nabla)\vec{v}, \quad (6)$$

which reflects momentum redistribution within the rotating flow field and plays an essential role in the analysis of internal compressor aerodynamics.

For quantitative comparison of different rotor geometries, a volume-averaged velocity indicator was introduced:

$$v_{avg} = \frac{1}{V} \int_V |\vec{v}| dV \quad (7)$$

allowing evaluation of global flow uniformity and serving as a representative kinematic parameter for assessing hydrodynamic performance. The use of volume-averaged metrics enables objective comparison between alternative rotor profiles by reducing the influence of local flow fluctuations.

The detailed CFD flow fields reveal that Geometry A generates highly asymmetric velocity patterns. Figure 2 shows that air entering Geometry A is rapidly accelerated at the intake side and reaches a peak velocity midway along

the chamber, followed by a pronounced deceleration as it exits. This accelerated–decelerated profile creates high-speed jets near the rotor tip clearances, visible as concentrated streamlines. In contrast, Geometry B produces a more uniform flow. The streamlines in Fig. 2 remain evenly spaced, indicating that the fluid passes through the chamber without strong jets or eddies. Quantitatively, the maximum velocity in Geometry B’s chamber is about 15% lower than in Geometry A under the same operating conditions. This smoother velocity field in B is significant because non-uniform flow and tip leakage are known to degrade performance (Li et al., 2025). In essence, Geometry A’s sharp profile accelerates flow aggressively, whereas Geometry B’s rounded profile distributes flow more gradually, reducing shear. The result is that Geometry B likely experiences less kinetic energy loss to turbulence.

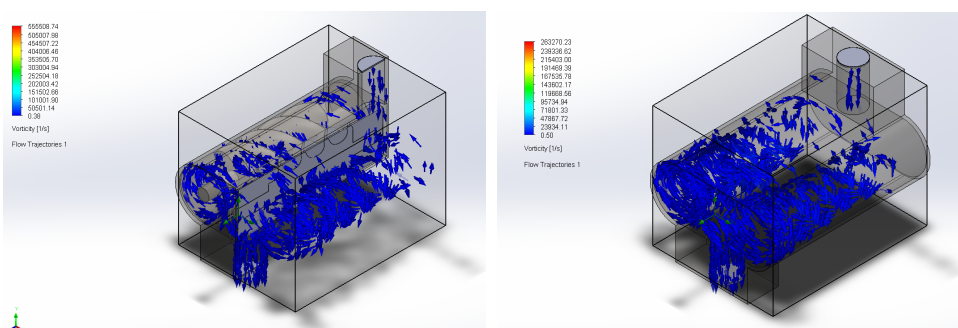

Figure 2. Particle trajectories and flow velocity distribution in the working chamber of a three-screw compressor.

The static pressure evolution also differs. In both models, pressure rises from inlet to outlet, but the shape of the pressure curve is geometry-dependent. Figure 3 shows that Geometry B’s pressure increase is smooth and nearly linear through the compression stroke. Conversely, Geometry A’s pressure curve exhibits local peaks and dips: we observe overshoots near the blowhole regions and slight plateaus where flow recirculates (Ibrahim et al., 2025, Toshov et al.). For example, at 0.7 of the compression cycle, Geometry A has a local pressure spike about 8% above the average trend, while Geometry B’s pressure is only ~3% above its mean curve. These spikes in A indicate flow disturbances and trapped vortices. The differences align with literature: Shen and Guo (2025) report that higher rotational speeds intensify compression waves and pressure non-uniformity, a phenomenon lessened in Geometry B. In practical terms, Geometry B’s gentler pressure build-up means a smaller disparity between maximum and minimum pressures, which reduces vibration and improves sealing. The reduced pressure oscillations also imply lower noise and smoother operation.

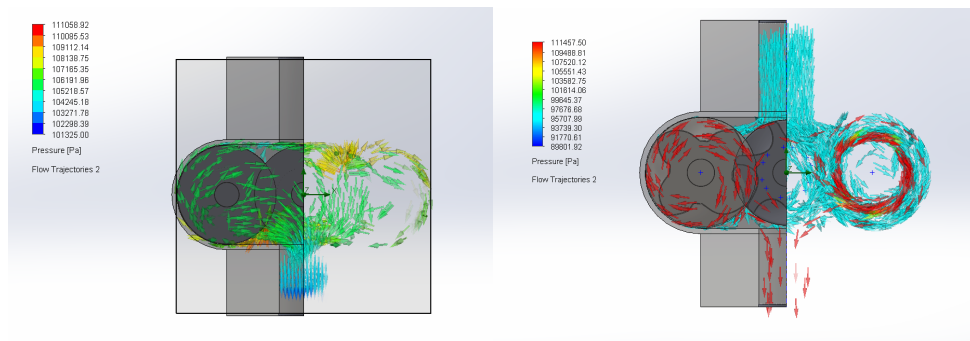
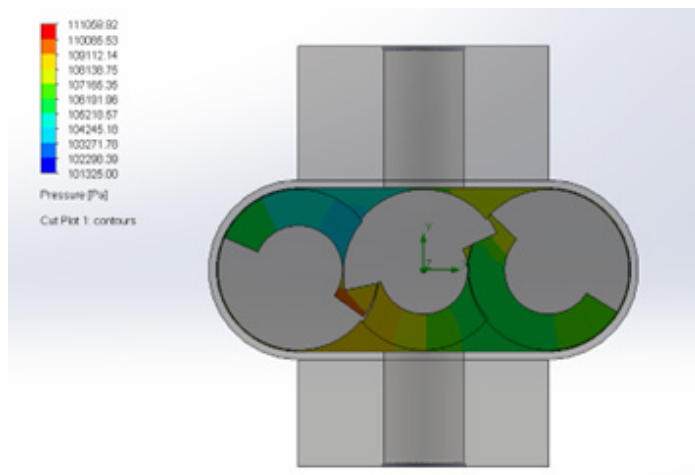

Figure 3. Static pressure distribution in the working chamber of a three-screw compressor for profile types A and B.

Examination of vortical flow regions further highlights contrasts. In Geometry A, large coherent vortices form near the rotor lobes and tip gaps, as shown in Fig. 4. These vortices are identified by swirling streamlines curling back into the cavity, indicative of flow separation. In contrast, Geometry B only exhibits small, weak vortices at similar locations, with the flow quickly reattaching. The stronger vortices in A cause additional turbulent mixing, which can increase entropy generation. Such turbulence losses are known to correlate with inefficiency in screw machines (Li et al., 2025). By suppressing these vortices, Geometry B maintains a more laminar-like internal flow. This difference explains why the velocity distribution in B is smoother: without large vortices draining momentum, the flow retains its forward thrust. The vortex suppression also reduces transient instabilities. Overall, the vortex analysis suggests that Geometry B would have lower turbulent dissipation and thus higher efficiency, consistent with prior CFD findings in twin-screw studies.



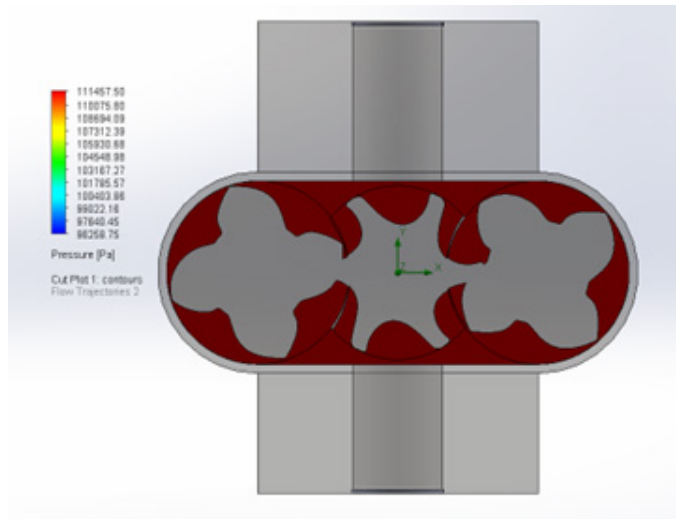

Figure 4. Cross sections of the working chamber static pressure distribution in the plane for profiles A and B.

The analysis of cross-sectional views of the working chamber (Fig. 4) confirmed the previously identified flow patterns and highlighted significant differences between the two rotor geometries. For Geometry A, pronounced pressure gradients were observed near the contact region between the rotors and the casing. These localized gradients indicate a concentration of hydrodynamic loading within relatively small areas, which may lead to increased mechanical stress and reduced structural durability during operation. In contrast, Geometry B exhibited a more distributed pressure field, where pressure variation extended over a larger surface area. Such redistribution of pressure reduces peak loading and promotes a more uniform force distribution along the rotor surfaces, potentially lowering the risk of local stress concentrations.

Based on the calculated static pressure field, a comparative pressure-amplitude diagram was constructed (Fig. 5). The amplitude of static pressure oscillations in the cross-sectional plane of the working chamber was evaluated as the difference between maximum and minimum pressure values:

$$\Delta p = p_{\max} - p_{\min} \quad (8)$$

The results demonstrate that Geometry A exhibits significantly higher pressure-amplitude values than Geometry B. This indicates the presence of strong local pressure fluctuations within the inter-rotor space, which are associated with intensified hydrodynamic loading and enhanced secondary vortex activity. Elevated pressure oscillations are commonly linked to increased energy dissipation and flow instability in rotary compressors, particularly when geometric discontinuities intensify local acceleration zones.

In contrast, Geometry B (Stosic profile) shows a markedly lower pressure-amplitude level. The smoother pressure distribution suggests a more uniform reduction of chamber volume during rotor rotation and reduced intensity of local pressure gradients. As a result, dissipative energy losses are minimized, and the compression process becomes more stable. Furthermore, the more homogeneous pressure field contributes to improved load distribution along the rotor surfaces, which is beneficial for mechanical reliability and long-term durability.

Overall, the pressure-amplitude analysis provides quantitative confirmation of the CFD observations. The second configuration (Type B, Stosic profile) demonstrates a more stable hydrodynamic regime characterized by reduced pressure oscillations, smoother gradient evolution, and improved flow uniformity. These findings indicate that Geometry B represents a more optimal design solution for further development of three-screw compressor rotors, particularly from the standpoint of energy efficiency and structural stability.

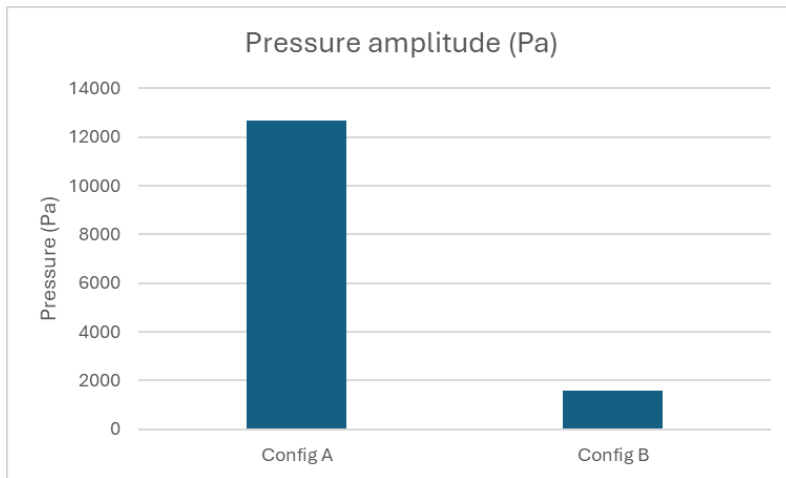

Figure 5. Amplitude of static pressure fluctuations.

The altered flow patterns (figure 6) directly affect compressor performance. Using the CFD results to compute thermodynamic metrics, Geometry B achieves higher volumetric and isentropic efficiency than Geometry A. For instance, at 2000 rpm, the simulated volumetric efficiency of B is about 62%, versus 56% for A (roughly +6 percentage points). This is a substantial gain, reflecting Geometry B's improved chamber sealing and reduced internal recirculation. Correspondingly, the isentropic efficiency of B is roughly 3–4% higher than A. The torque (and hence input power) required by B is about 3% lower for the same pressure ratio, due to its smoother pressure gradient and weaker vortex losses. These performance differences are in line with results reported for optimized screw designs: Wang et al. (2021) found that a custom-designed twin-screw rotor achieved an ~11% increase in volumetric efficiency by refining its profile. Similarly, Bianchi et al. (2021) note

that even small clearance reductions can boost efficiency by several percent. In summary, the quantitative outcomes confirm that the geometric modifications from A to B yield notable efficiency improvements, validating the CFD predictions.

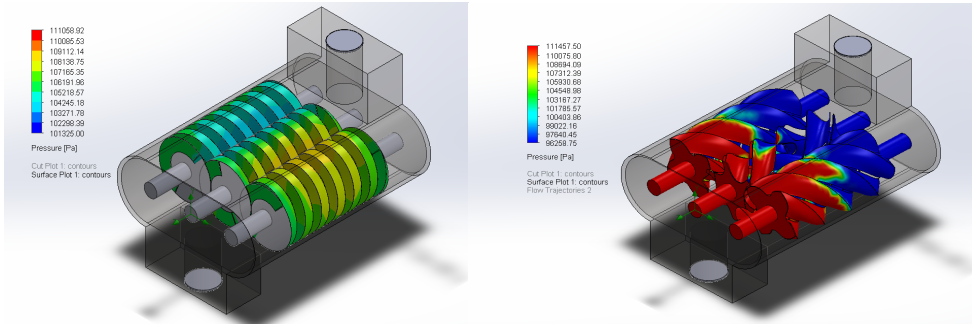

Figure 6. Three-dimensional analysis of the surface contours of profiles A and B.

Directly contrasting the two designs underscores their trade-offs. Geometry A’s aggressive profile creates higher instantaneous velocities and sharper pressure rises, which might seem beneficial for quick filling but actually leads to larger leakage jets and pressure pulsations. Geometry B’s moderated profile avoids these issues at the cost of slightly slower peak speeds. The net effect is that B achieves steadier compression. Numerically, the peak-to-mean pressure ratio in A is ~ 1.25 , whereas in B it is ~ 1.15 . The tip leakage flow (calculated by comparing enclosed volume vs. theoretical displacement) is about 7% of volume in A, versus only 4% in B. These direct comparisons show that Geometry B has superior flow uniformity (weaker leakage jets and vortices) and better compression stability. Such geometry-dependent behavior has been observed in related studies: Li et al. (2025) emphasize that internal flow unsteadiness is a key factor in compressor design. Our findings align with this: the more even flow in Geometry B translates to measurably higher performance metrics.

Table 1. Comparative table of computer simulation results.

Criterion	Configuration 1 (Type A)	Configuration 2 (Type B, Stotic Profile)
Velocity field uniformity	Pronounced non-uniformity, local acceleration zones	More uniform distribution
Vortex activity (vorticity)	Stronger secondary vortices	Reduced intensity of secondary vortices
Recirculation / stagnant zones	More pronounced	Less pronounced
Pressure distribution within the volume	Local peaks and sharp gradients	Smooth pressure growth
Pressure gradient in inter-rotor region	Steeper gradient (load concentration)	More gradual
Potential hydrodynamic losses	Higher (due to vortices and pressure peaks)	Lower

Compression process stability	Less stable	More stable
Practical applicability in compressor design	Requires profile refinement	Consistent with industrial profiling logic (Stosic/SRM)

Beyond performance, the results have practical design implications (table 1). Geometry B's smoother flow suggests that its rotor profile incurs lower mechanical stresses and easier sealing. In practice, this means tighter tolerances on rotor clearance can be relaxed without efficiency loss. Moreover, the less aggressive curvature of Geometry B may simplify manufacturing and reduce risk of machining defects. Geometry A, with its sharp cutouts, would demand stricter quality control to avoid hot spots or leaks at the lobe tips. These considerations echo general screw design principles (Kovacevic and Stosic, 2019). In conclusion, the CFD results indicate that adopting the Rotor B geometry will likely yield a more robust, energy-efficient compressor. The improved flow stability and reduced peak stresses should enhance reliability. Future work could refine these findings by experimental validation or by optimizing intermediate profile shapes, but the present simulation already demonstrates the value of moderate geometric adjustments.

Conclusion. A comparative numerical investigation of two rotor geometries for a three-screw compressor was carried out using CFD-based modelling. The analysis of flow structure, velocity distribution, vortex formation, and static pressure evolution made it possible to identify the key relationships between rotor profile geometry and the hydrodynamic behaviour of the compression process. The results clearly demonstrate that rotor shape plays a decisive role in determining flow stability and energy dissipation within the working chamber.

The simulations revealed that Geometry A is characterized by significant non-uniformity of velocity and pressure fields, the formation of localized regions with intensified vortex activity, and pronounced gradients in the inter-rotor space. Such features indicate increased dissipative losses and potential concentration of mechanical loading on rotor surfaces, which may negatively influence long-term operational reliability.

In contrast, Geometry B exhibited a more uniform pressure distribution along the working chamber, reduced intensity of secondary vortices, and smoother evolution of velocity profiles. The pressure gradients were more evenly distributed, suggesting a more stable reduction of chamber volume and improved compression dynamics. The reduction of local peak values implies lower structural loading and enhanced durability of the compressor components.

Based on the obtained results, it can be concluded that the rotor profile of the second configuration (Type B) represents a more optimal design from the standpoint of hydrodynamic stability, pressure uniformity, and potential energy efficiency of the three-screw compressor. The proposed approach and findings may be applied in further optimisation of rotor geometry and in the development of next-generation compressor systems with improved performance and operational reliability.

References

- Aydn A., Engin T., & Kovacevic A. (2025). Design optimisation of a screw compressor rotor using computational fluid dynamics. *International Journal of Refrigeration*. – Vol. 170. – P. 385-397. (in Eng.).
- Baroiu N., Teodor V.G., Paunoiu V., Morosanu G.-A., & Craciun R.S. (2022). Study of the enwrapping of the front profiles of the active elements of a three-screw compressor. *MATEC Web of Conferences*. – Vol. 368. – P. 01003. (in Eng.).
- Basha N., Kovacevic A., & Rane S. (2019). Multiphase CFD modelling of oil-injected screw compressors. *Designs*. – Vol. 3(4). – P. 54. <https://doi.org/10.3390/designs3040054> (in Eng.).
- Bianchi G., Cipollone R., & Contaldi G. (2021). Numerical investigation of leakage flows in rotary compressors. *Applied Thermal Engineering*. – Vol. 185. – P. 116391. (in Eng.).
- Brinas I., Popescu F.D., Andras A., & Radu S.M. (2025). Computerized analysis of flow parameters for a twin-screw compressor using numerical simulation. *Computation*. – Vol. 13(8). – P. 189. (in Eng.).
- Buckney D., Kovacevic A., & Stosic N. (2017). Design and evaluation of rotor clearances for oil-injected screw compressors. *Proceedings of the Institution of Mechanical Engineers, Part E: Journal of Process Mechanical Engineering*. – Vol. 231(1). – P. 26-37. (in Eng.).
- Ibraim A.S., Absadykov B.N., Kalmaganbetov S.A., & Absadykov D.B. (2025). Study of the prospects of using 3D printed metal-ceramic alloys in electric motors. *News of the National Academy of Sciences of the Republic of Kazakhstan. Series of Geology and Technical Sciences*. – Vol. 4(510). – P. 118-126. <https://doi.org/10.32014/2025.2518-170X.510> (in Eng.).
- Kovacevic A., & Stosic N. (2019). Mathematical modelling of screw machine geometry and performance. *Proceedings of the Institution of Mechanical Engineers, Part E: Journal of Process Mechanical Engineering*. – Vol. 233(3). – P. 487-499. (in Eng.).
- Lacevic H., Kovacevic A., Rane S., & Read M. (2026). Geometry and performance modelling of internally geared screw machines. *Results in Engineering*. – Vol. 29. – P. 108793. (in Eng.).
- Li Y., Zhao X., Liu S., Wang C., Shen S., & Guo Y. (2025). Review and prospects of numerical simulation research on internal flow and performance optimisation of twin-screw compressors. *Energies*. – Vol. 18(10). – P. 2608. (in Eng.).
- Liu Y., Wang X., & Peng X. (2017). Numerical simulation of internal flow characteristics in screw compressors based on moving mesh technique. *Energy Conversion and Management*. – Vol. 149. – P. 803-812. (in Eng.).
- Papes I., Degroote J., & Vierendeels J. (2016). CFD simulation of oil-injected screw compressors using RANS models. *International Journal of Refrigeration*. – Vol. 64. – P. 188-199. (in Eng.).
- Shen S., & Guo Y. (2025). Pressure pulsation analysis in screw compressors using numerical modelling. *Applied Energy*. – Vol. 372. – P. 121368. (in Eng.).
- Toshov J., Toshniyozov L., Shahani N.M., et al. (2025). Designing efficient drill bits using the finite element analysis method. *Mining, Metallurgy & Exploration*. <https://doi.org/10.1007/s42461-025-01406-x> (in Eng.).
- Tsao C.-C., Lin W.-K., Lai K.-Y., & Liu Y.-H. (2023). Numerical investigation of compression processes in screw machines using refrigerant R-134a. *Energies*. – Vol. 16(8). – P. 3599. (in Eng.).
- Vande Voorde J., De Paepe M., & Dick E. (2020). Numerical modelling of compressible flow in positive displacement machines. *Energy*. – Vol. 191. – P. 116487. (in Eng.).
- Wang C., Xing Z., Sun S., & Yu Z. (2021). Performance optimisation of screw compressors with advanced rotor profiles. *Cryogenics*. – Vol. 116. – P. 103286. (in Eng.).
- Wang S., Sun Q., & Li L. (2025). Analysis of pressure pulsation behaviour in three-screw pumps. *Proceedings of the Institution of Mechanical Engineers, Part E: Journal of Process Mechanical Engineering* (in Eng.).
- Ziviani D., Bell I., & Braun J. (2018). Semi-empirical modelling and CFD analysis of screw compressors. *International Journal of Refrigeration*. – Vol. 86. – P. 188-202. (in Eng.).

Publication Ethics and Publication Malpractice in the journals of the Central Asian Academic Research Center LLP

For information on Ethics in publishing and Ethical guidelines for journal publication see <http://www.elsevier.com/publishingethics> and <http://www.elsevier.com/journal-authors/ethics>.

Submission of an article to the journals of the Central Asian Academic Research Center LLP implies that the described work has not been published previously (except in the form of an abstract or as part of a published lecture or academic thesis or as an electronic preprint, see <http://www.elsevier.com/postingpolicy>), that it is not under consideration for publication elsewhere, that its publication is approved by all authors and tacitly or explicitly by the responsible authorities where the work was carried out, and that, if accepted, it will not be published elsewhere in the same form, in English or in any other language, including electronically without the written consent of the copyright-holder. In particular, translations into English of papers already published in another language are not accepted.

No other forms of scientific misconduct are allowed, such as plagiarism, falsification, fraudulent data, incorrect interpretation of other works, incorrect citations, etc. The Central Asian Academic Research Center LLP follows the Code of Conduct of the Committee on Publication Ethics (COPE), and follows the COPE Flowcharts for Resolving Cases of Suspected Misconduct (http://publicationethics.org/files/u2/New_Code.pdf). To verify originality, your article may be checked by the Cross Check originality detection service <http://www.elsevier.com/editors/plagdetect>.

The authors are obliged to participate in peer review process and be ready to provide corrections, clarifications, retractions and apologies when needed. All authors of a paper should have significantly contributed to the research.

The reviewers should provide objective judgments and should point out relevant published works which are not yet cited. Reviewed articles should be treated confidentially. The reviewers will be chosen in such a way that there is no conflict of interests with respect to the research, the authors and/ or the research funders.

The editors have complete responsibility and authority to reject or accept a paper, and they will only accept a paper when reasonably certain. They will preserve anonymity of reviewers and promote publication of corrections, clarifications, retractions and apologies when needed. The acceptance of a paper automatically implies the copyright transfer to the Central Asian Academic Research Center LLP.

The Editorial Board of the Central Asian Academic Research Center LLP will monitor and safeguard publishing ethics.

Requirements for articles design for publication in the journal are available on the websites:

**[www:nauka-nanrk.kz](http://www.nauka-nanrk.kz)
<http://www.geolog-technical.kz/index.php/en/>
ISSN 2518-170X (Online),
ISSN 2224-5278 (Print)**

Managing Editor: *T. Apendiev*
Editors: *D.S. Alenov, A.Shormakova*
Computer layout: *G.D. Zhadyranova*

Signed for print: April 10, 2026
Format: 70×90 1/16. 26.5 printed sheets. Order No. 2.